



# PHILIPP Noise Reduction System

---

## Installation Instruction



Mounting Distances 20mm up to 80mm

Permissible values according to DIN 1045-1

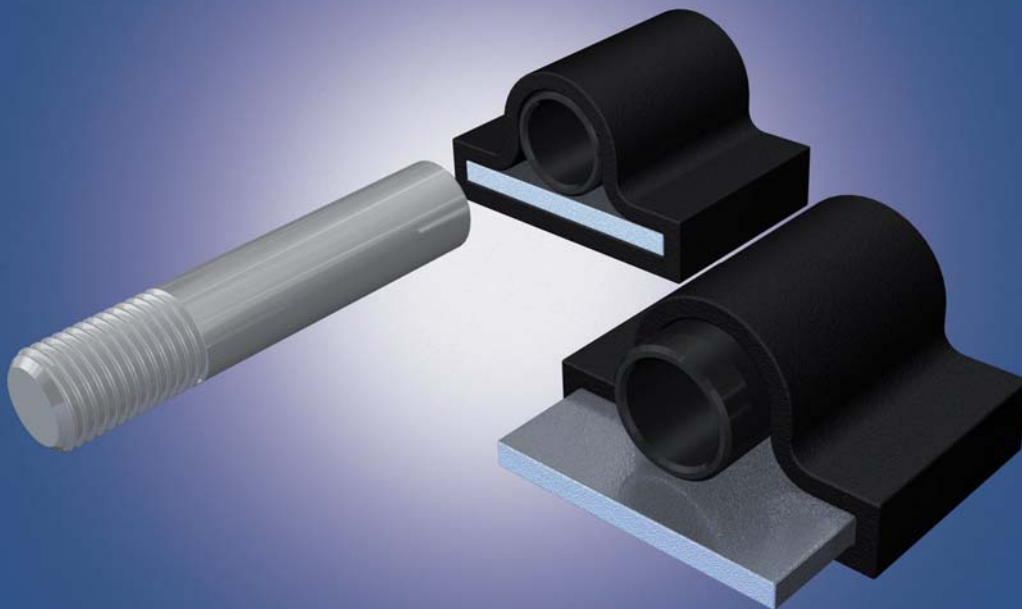

## Transport and Mounting Systems for Precast Units

- ▲ **Technical department** – our staff will be pleased to support you during your design process with suggestions for installation and use of our transport and mounting systems for precast units.
- ▲ **Special constructions** – individual for your special application.
- ▲ **Practical tests in plant** – we ensure that our concepts are customized.
- ▲ **Test reports** – for documentation and your safety.
- ▲ **Service** – our engineers will be pleased to train your technicians and staff at plant, consult during installation of precast units and help to optimize the production process.
- ▲ **High application safety of our products** – close cooperation with federal institute for material testing and – where required – German approvals of our products.
- ▲ **Software solutions** – design software for our sandwich anchor system.

▲ **Technical Department:**

Phone: +49 (0) 6021 / 40 27-318  
Fax: +49 (0) 6021 / 40 27-329  
Email: [technik@philipp-gruppe.de](mailto:technik@philipp-gruppe.de)

▲ **Sales Department:**

Phone: +49 (0) 6021 / 40 27-300  
Fax: +49 (0) 6021 / 40 27-440  
Email: [export@philipp-gruppe.de](mailto:export@philipp-gruppe.de)



# Contents

---

Description of the System .....	Page 4
Installation Advice .....	Page 5
Minimum Unit Dimensions .....	Page 7
Reinforcement .....	Page 7
Requirements of the Bearing Area .....	Page 8
Noise Reduction .....	Page 8
Fire Protection .....	Page 9
Bearing Capacity of the System .....	Page 10
Anchor Overview .....	Page 11



## Description of the System

The **PHILIPP Noise Reduction System** is used as bearing in walls of spiral or straight staircases, ceilings and landings. The installation in beam-shaped units and brackets is also possible.

The approval considers the use of the system in inside units loaded by primarily static forces. We are pleased to provide you with more information about the requirements for the use in outside units.

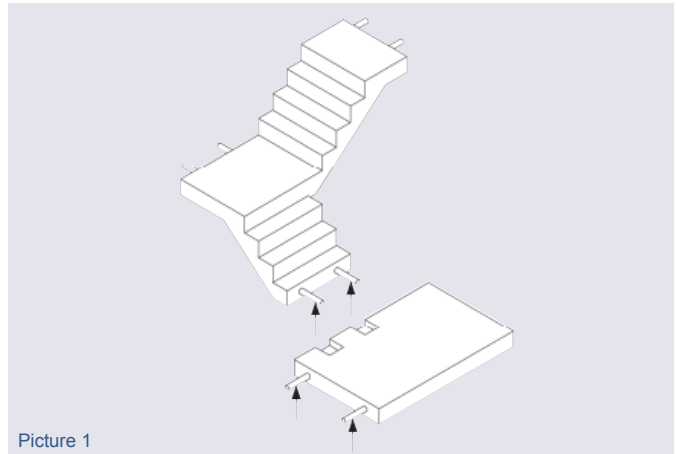

Picture 1

The **PHILIPP Noise Reduction System** consists of single components (Picture 2). These components are the **PHILIPP Threaded Anchors** (Picture 1), threaded bolts which are screwed into the anchor and the noise reduction bearing. This bearing lays in an elastomer made of neoprene to achieve an optimal load distribution. The load is transferred through the elastomer into the bearing (e.g. masonry, concrete).

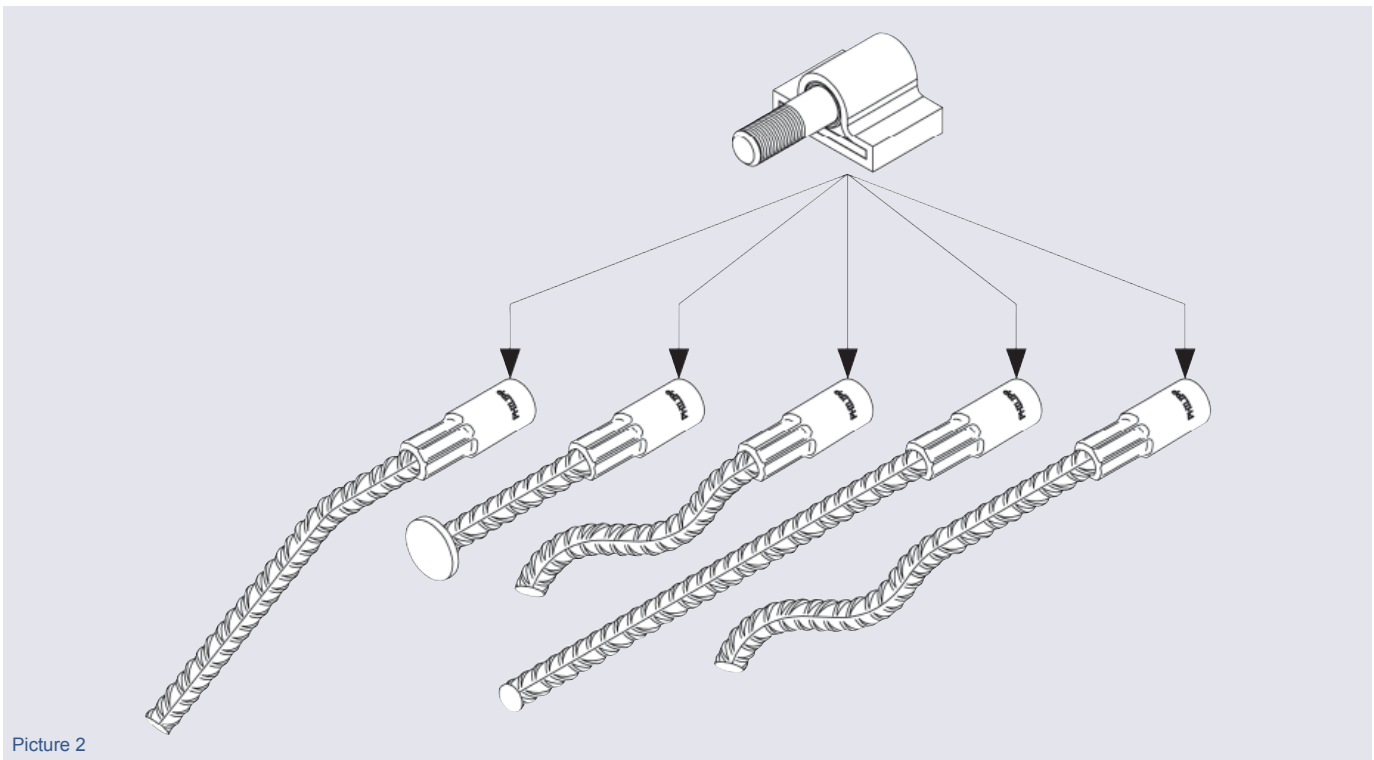

Picture 2

The numerous anchor variations offer the user the possibility to use the **PHILIPP Noise Reduction System** for difficult precast constructions. Both, long and short anchors can be installed in plane landings. Short and bent anchors are used for coiled or angled staircases. The **PHILIPP Noise Reduction System** is the only system which gives the user the opportunity to bend the long anchors to adjust it for different slopes. Stair constructions with complex and difficult installations of the anchor now belong to the past. It must be considered that the distance of the bending to the insert has the 5-fold rebar diameter.

# INSTALLATION INSTRUCTION OF PHILIPP NOISE REDUCTION SYSTEM

If the anchor is already bent during manufacture by PHILIPP the measure can be decreased to the double rebar diameter (Picture 3). The bent bars must be anchored in the concrete in the compression area. The anchor lengths given in Picture 3 are minimum values. Longer versions of the anchors can also be used. The required bending roll diameter according to German standard (DIN 1045-1) must be 7 times the rebar diameter ( $7 \times 25\text{mm} = 175\text{mm}$ ).

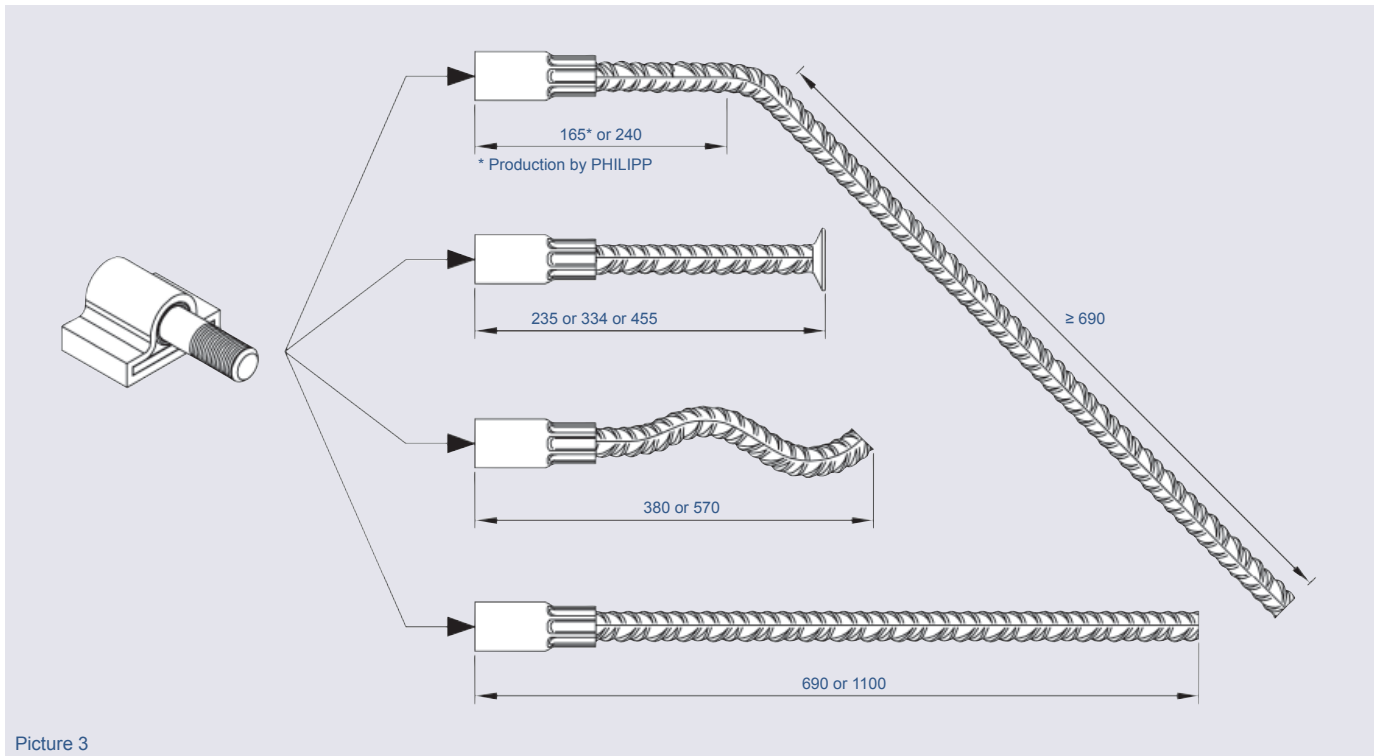

Picture 3

## Installation Advice

During installation the threaded bolt is screwed in by hand until the inset is reached. This can be done prior or after mounting of the staircase. The recess in the wall must be arranged depending on the condition at site. It must be taken into account that different mounting distances "a" (Picture 4) require different bolt lengths. Finally, the bearing is pushed so far that the end of the bolt has contact with the last cladding. A mortarboard, in which the insulation body is installed, balances small unevenness. To ensure an uniform levelling it is also possible to underlay steel plates. The grouting of the recess is necessary to ensure the durability of the bearing. Please pay attention that no sound transmission connection occurs during grouting.

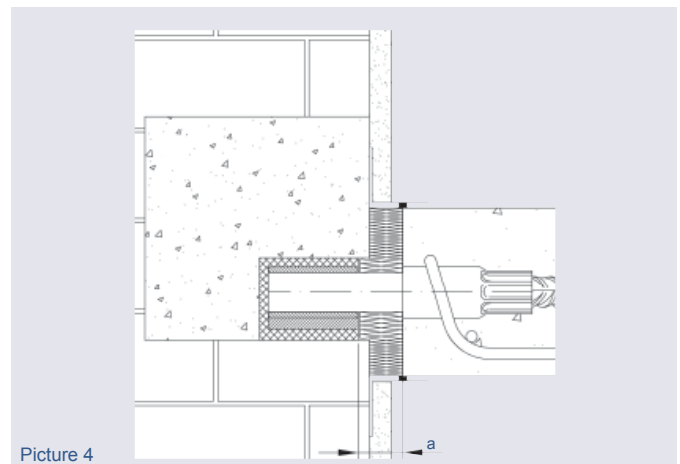

Picture 4

For the different mounting distances “a” a suitable bolt length according to Table 1 has to be used. The mounting distance “a” is defined as distance between the threaded anchor in the unit and the leading edge of the noise reduction bearing (Picture 4).

**Table 1: Dimensions and Mounting Distances  
(Picture 4 and 5)**

Thread	Thread Length e [mm]	Mounting Distance a [mm]	Bolt Length L [mm]
M36	60	20	160
		40	180
		50	190
		60	200
		70	210
		80	220

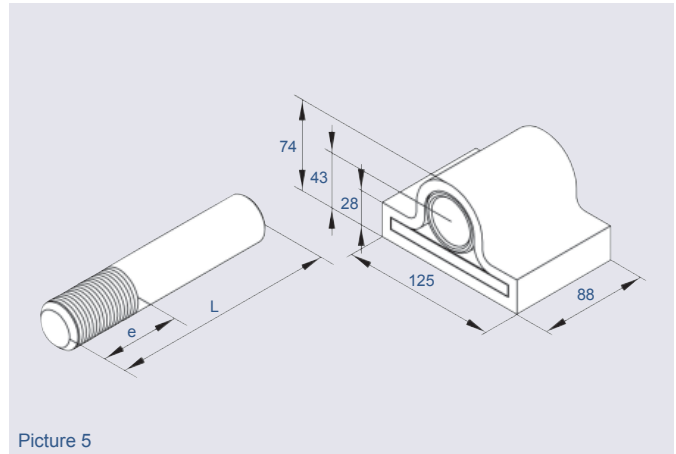

There are different possibilities to install the **PHILIPP Noise Reduction System** (Picture 6). The required lateral reinforcement for the anchor insert must be installed in a horizontal position. The reinforcement for the load induction is not shown in Picture 6 but is mentioned in the next sections.

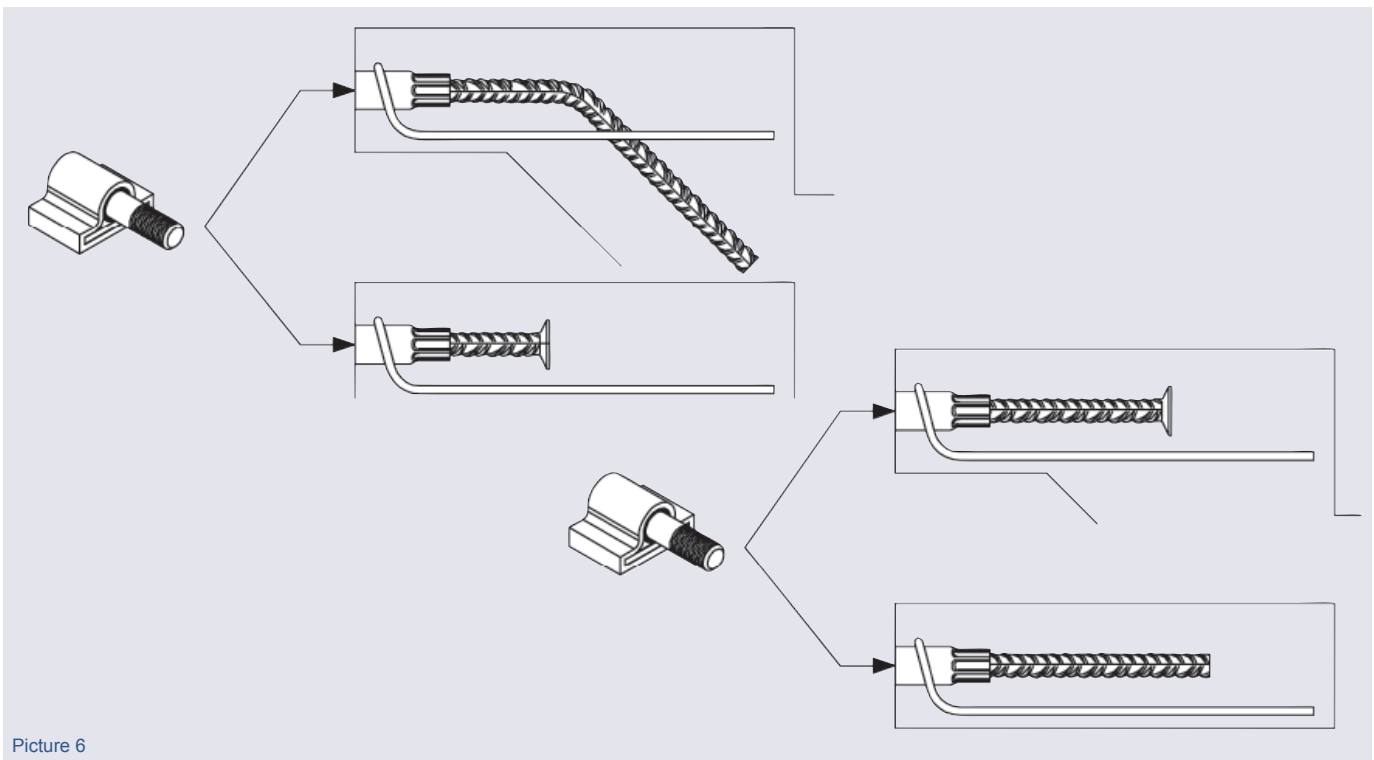

## Minimum Unit Dimensions

The unit thicknesses and distances given in Table 2 are minimum dimensions. It is not admissible to undergo these values! However, an extension of the minimum unit thicknesses and distances from the edge and in between is possible. The anchor is always installed in the unit in a centre position (e.g. stair landing, slabs, beams, consoles). If the noise reduction bearings lay very close in one row the continuity effect must be taken into account. The engineer must consider these values in his calculations and proof them in the adjacent units.

**Table 2: Minimum Unit Thicknesses (Picture 7)**

Minimum Unit Thickness $d$ [mm]	Edge Distance $e_2$ [mm]	Axial Distance $e_1$ [mm]
150	100	200

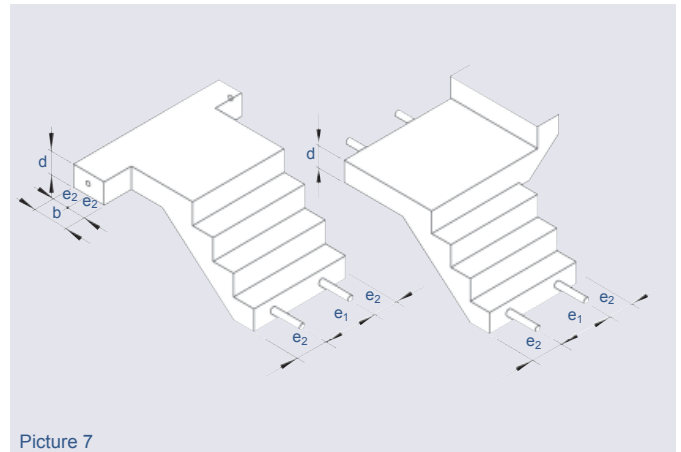

Picture 7

## Reinforcement

For the load transmission into the plate a special reinforcement is required. A back hanging stirrup ① with a diameter of 10mm ensures the load transmission into the plate. This stirrup must have pressure contact with the threaded insert. Additionally to the stirrup a rebar ② with diameter of 10mm must be laid in between anchor, insert and stirrup (Picture 8). The design of the console and plate for the local load induction and the transmission of the acting forces into the unit have to be made by the engineer according to DIN 1045-1. All adjacent units (e.g. masonry, reinforcement concrete units) have to be proofed by the engineer.

**Table 3: Dimensions of Additional Reinforcement**

Back Hanging Reinforcement ① dia. $d_s$	H [mm]	B [mm]
10	$\geq 92$	520

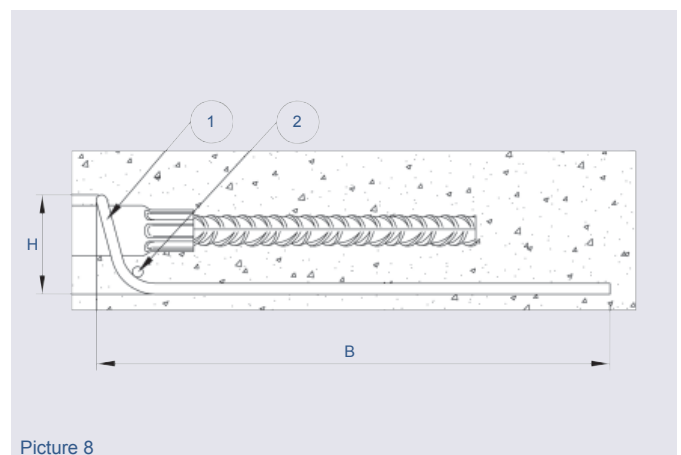

Picture 8

Alternatively to the proof of the local load induction by the engineer it is possible to install the following reinforcement. Further calculations for the local load induction of the bearing forces can be neglected. Thereby it is not important if the load is transferred into the console or the plate. The mentioned additional rebar ② can be neglected using this kind of reinforcement.

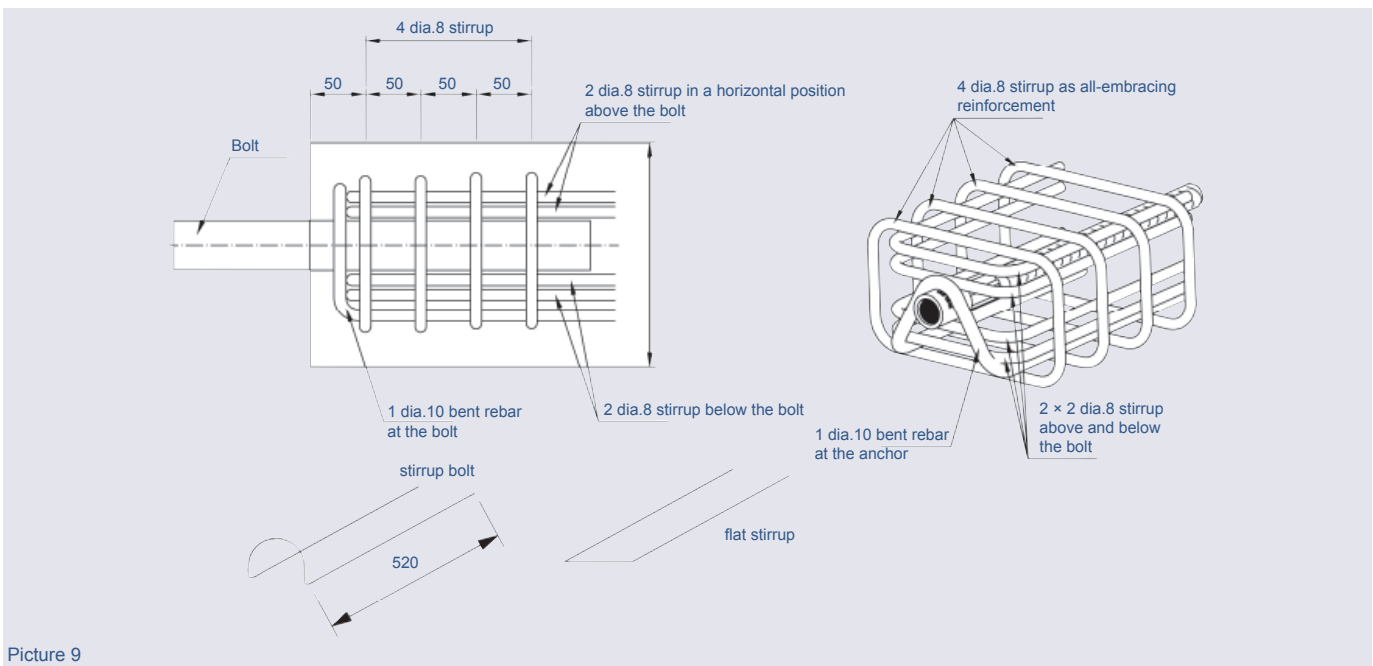

Picture 9

## Requirements of the Bearing Area (Masonry)

The resulting surface pressure of the insulation body must be absorbed by an appropriate bearing of the building. The position of the resulting force at the bearing has to be proofed by the engineer. For the bearing a concrete bed or high quality masonry can be used. For the positioning the advice of "Heft 525" must be considered. The basic values for the allowed compression stresses according to DIN 1053 with the particular mortar classes are given as follows. The reduction factor is assumed with 1.0. The basic values of the allowed compression stress must be corrected if k deviates.

$$\text{requ. } \sigma_{D_{\text{wall}}} = 2,14 \text{ N/mm}^2 = k \times \sigma_0$$

According to DIN 1053 "Design of Masonry (simplified method)"

**k = 1,0 reduction factor (assumption)**

**$\sigma_0$  = basic value of the allowed compression stress**

**required brickwork strength (SF) with mortar class at k=1.0  $\geq$  SF28 / NM IIa**

If the requirements of DIN 1053 T1 Section 7.2.3 are fulfilled the masonry stress can be assumed with  $\sigma_0$ = basic value according to Table 3 (DIN 1053 T1) for the area under the bearing.

## Noise Reduction

The application of the **PHILIPP Noise Reduction System** ensures the increased noise reduction according to DIN 4109 (Sheet 2). In comparison to the conventional bearings a considerable reduction of the noise is achieved. The standardized allowed impact noise was determined by ITA ("Ingenieurgesellschaft für technische Akustik mbH"). Table 4 shows the improvement of impact noise measure of **PHILIPP Noise Reduction System**.

**Table 4: Improvement of Impact Noise Measure**

Required Noise Reduction acc. to DIN 4109 [dB]	Required Increased Noise Reduction Sheet 2 of DIN 4109 [dB]	Achieved Noise Reduction of PHILIPP Noise Reduction System [dB]	Improvement of Impact Noise Measure of PHILIPP Noise Reduction System Relating to DIN 4109 [dB]
requ. $L'_{n,w}$ 58	requ. $L'_{n,w}$ 46	exist. $L'_{w,R}$ 39-42	$\Delta L_{w,R}$ 16-19



## Fire Resistance

The construction of the **PHILIPP Noise Reduction System** complies with fire resistance class F90 (fire resistant for 90 minutes) according to DIN 4102-2.

An expert's evaluation was made by the "Materialprüfanstalt für das Bauwesen Braunschweig Nr. 5177/2006" to confirm this. The existing air gap between staircase and bearing is filled with fire-proof mineral wool. The mineral wool must be positioned around the bolt with a breath of 50mm. This ensures the required fire resistance class.

To avoid a falling out of the mineral wool an angle is installed between plaster and staircase. Silicon between angle and staircase avoids a sound transmission connection. The recess in the wall is filled completely with fire resistant grouting mortar (mortar class II/IIa or III/IIIa according to German Standard) after installation of the bearing. If there are larger distances between wall and staircase the mineral wool must be arranged respectively. During grouting please pay attention that no sound transmission connection occurs between bolt and grouting mortar.

The **PHILIPP Noise Reduction System** is not suitable for buildings with increased fire resistance requirement. It has an expert's evaluation for the fire resistance class "F90" according to DIN 4102-2 if the reinforced concrete staircase and reinforced concrete landing fulfil the requirements of DIN 4102-2. The wall next to the bearing must be designed for fire resistance F90 according to DIN 4102. The interior plaster must comply with the requirements of DIN 4102-4 section 3.1.6

**Table 5: Density of Mineral Wool**

Mounting Distance a* [mm]	Thickness Steel Plate t [mm]	Density of Fire - proof Mineral Wool [kg/m <sup>3</sup> ]	Melting Point of Mineral Wool [°C]
≤ 20	1	≥ 80	≥ 1000
> 20	1	≥ 150	≥ 1000

(\* Distance between threaded anchor and noise reduction bearing (Pictures 4 and 10))

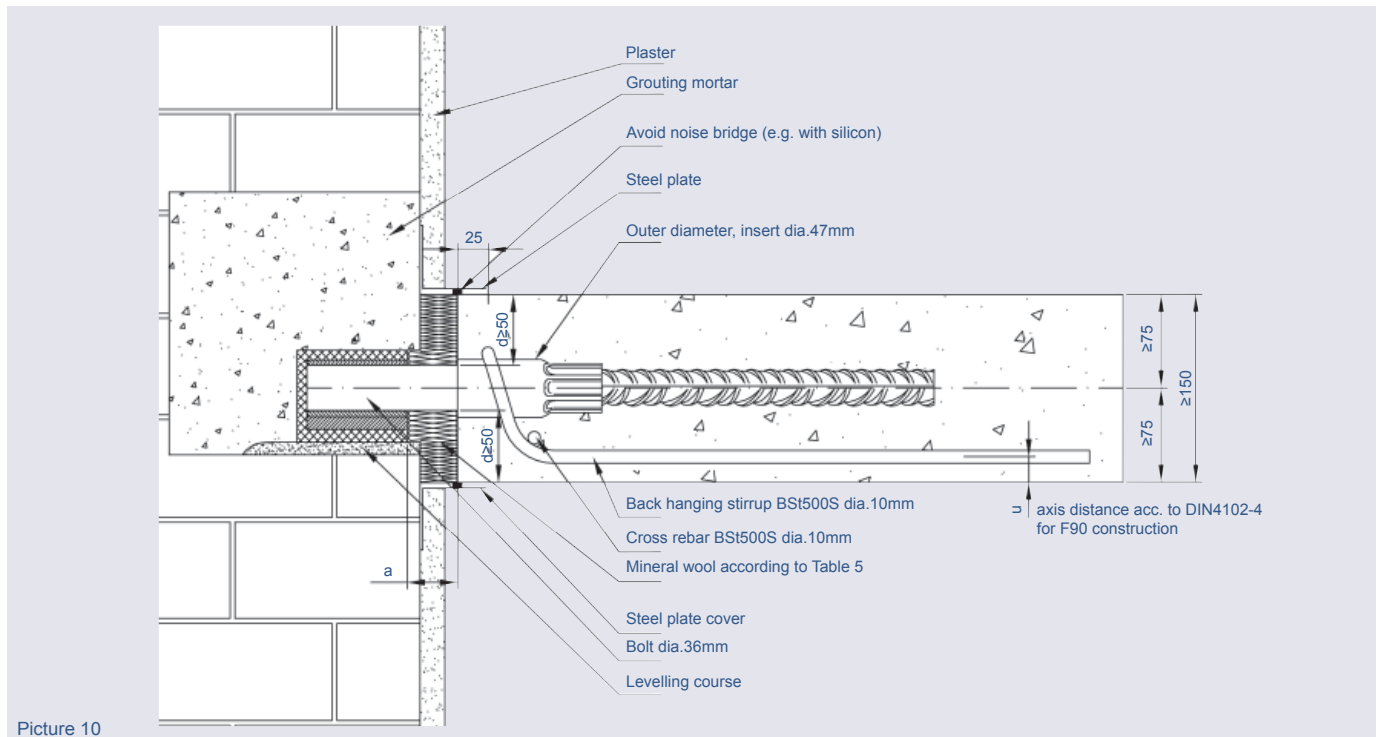

Picture 10

## Maximum Bearing Capacity

The **PHILIPP Noise Reduction System** is suitable for primarily static loads. The allowed bearing loads vary depending on the used concrete strength (stairs or landing), the mounting distance “a” (Picture 4) and the material of the threaded bolt. The mounting distance “a” is defined as distance between threaded anchor in the concrete unit and leading edge of the noise reduction bearing (Picture 4). Thereby it must be paid attention that the noise reduction bearings are pushed over the bolt and have contact with the last cladding of the bolt. With an optimal selection of the material the following combinations result under consideration of the single calculations for the bearing capacity of the system. Table 6 and 8 are valid for the combinations shown in Picture 2.

**Table 6: Overview Bearing Capacity for Bolt S355**

Art.-No.	Bolt Length L [mm]	Mounting Distance a [mm]	Allowed $V_{Rd}$ [kN]	Material Concrete - Bolt
670TSSG160	160	20	24.6	C20/25 - S355
670TSSG180	180	40	18.6	C20/25 - S355
670TSSG190	190	50	16.4	C20/25 - S355
670TSSG200	200	60	14.8	C20/25 - S355
670TSSG210	210	70	13.4	C20/25 - S355
670TSSG220	220	80	12.3	C20/25 - S355

**Table 7: Overview Bearing Capacity for Bolt GK 8.8**

Art.-No.	Bolt Length L [mm]	Mounting Distance a [mm]	Allowed $V_{Rd}$ [kN]	Material Concrete - Bolt
670TSSG1608.8*	160	20	34.9	C30/37 - GK8.8
670TSSG1808.8*	180	40	29.8	C30/37 - GK8.8
670TSSG1908.8*	190	50	26.5	C30/37 - GK8.8
670TSSG2008.8*	200	60	23.8	C30/37 - GK8.8
670TSSG2108.8*	210	70	21.7	C30/37 - GK8.8
670TSSG2208.8*	220	80	19.9	C30/37 - GK8.8

**Table 8: Overview Bearing Capacity for Bolt Stainless Steel**

Art.-No.	Bolt Length L [mm]	Mounting Distance a [mm]	Allowed $V_{Rd}$ [kN]	Material Concrete - Bolt
670TSSG160VA*	160	20	34.6	C30/37 - S690
670TSSG180VA*	180	40	26.0	C30/37 - S690
670TSSG190VA*	190	50	23.1	C30/37 - S690
670TSSG200VA*	200	60	20.8	C30/37 - S690
670TSSG210VA*	210	70	18.9	C30/37 - S690
670TSSG220VA*	220	80	17.3	C30/37 - S690

**Table 9: PHILIPP Noise Reduction System  
(complete construction set)**

Art.-No.	Mounting Distance [mm]	b [mm]	t [mm]	$h_1$ [mm]	$h_2$ [mm]	$h_3$ [mm]
67TSE	20 - 80	125	88	28	43	74

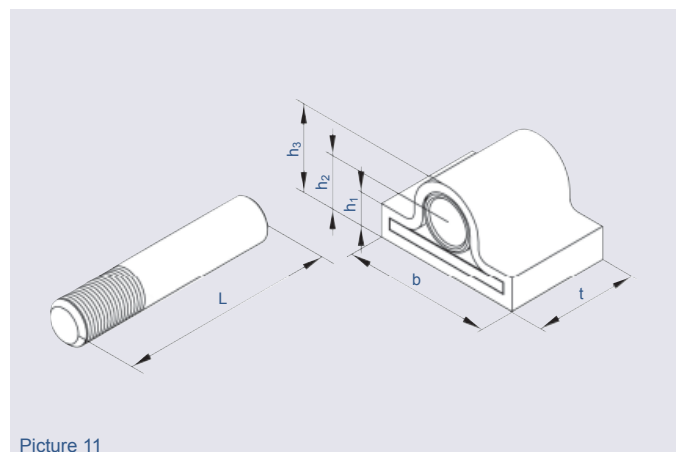

Picture 11

\* Delivery time on request

**Table 10: Threaded Anchor (straight)**

Art.-No.	Type	dia.D	h	d <sub>s</sub>
galvanized	RD	[mm]	[mm]	[mm]
67M36	36	47	690	25
67M361100	36	47	240	25

Suitable to be bent by user (please pay attention to page 4 and 5 as well as Picture 3)

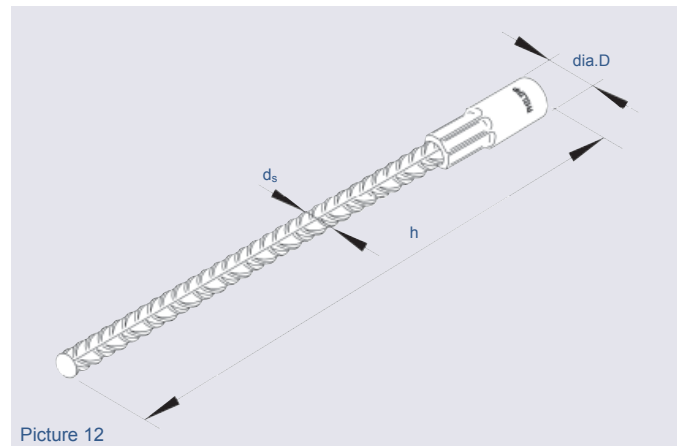

Picture 12

**Table 11: Threaded Anchor (wavy tail)**

Art.-No.	Type	dia.D	h	d <sub>s</sub>
galvanized	RD	[mm]	[mm]	[mm]
67M36WE	36	47	570	25
67M36K	36	47	380	25

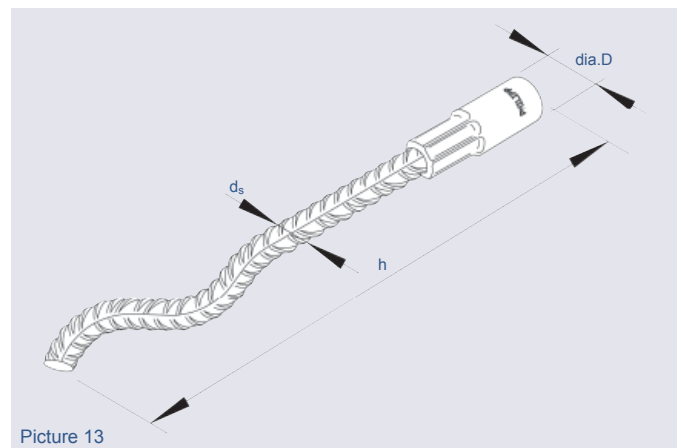

Picture 13

**Table 12: Compact Anchor**

Art.-No.	Type	dia.D	dia.D <sub>1</sub>	h	d <sub>s</sub>
galvanized	RD	[mm]	[mm]	[mm]	[mm]
67K360235	36	47	60	235	25
67K360334	36	47	60	334	25
67K360450	36	47	60	450	25

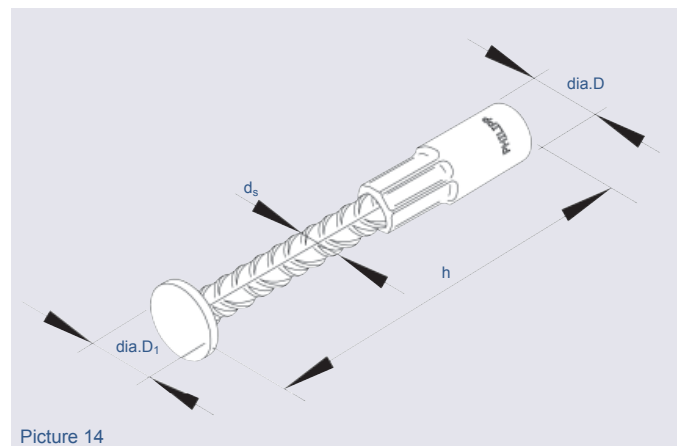

Picture 14

**Table 13: Threaded Anchor (bent version)**

Art.-No.	Type	dia.D	d <sub>s</sub>	h	l
galvanized	RD	[mm]	[mm]	[mm]	[mm]
67M360850GK	36	47	25	165	690

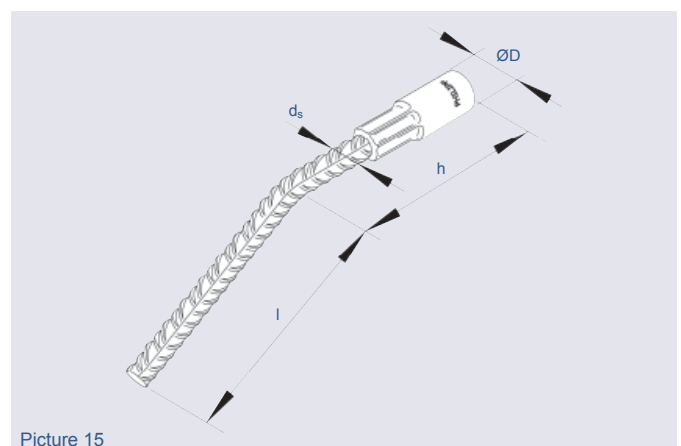

Picture 15

## Ropes

- ▲ wire rope slings
- ▲ crane and forest ropes
- ▲ wire, hemp and polyamide ropes
- ▲ hoisting and special ropes
- ▲ polypropylene ropes
- ▲ rope connections



## Lifting, attachment and lashing equipment

- ▲ load restraint systems
- ▲ RUD sling chains
- ▲ load suspension devices
- ▲ round slings, sling bands and lifting equipment
- ▲ rope and chain accessories
- ▲ lifting beams



## Transport and mounting systems for prefabricated units

- ▲ transport anchors
- ▲ spherical-head anchor system
- ▲ fixing sockets
- ▲ connecting technique



## Hydraulic, pneumatics and conveyor technique

- ▲ hydraulic units and components
- ▲ pneumatic, connector systems and accessories
- ▲ Hoses, fittings and accessories
- ▲ machines, tools, machinery systems and accessories

**PHILIPP GmbH**  
Lilienthalstrasse 7-9  
D-63741 Aschaffenburg  
Tel: + 49 (0) 6021 / 40 27-0  
Fax: + 49 (0) 6021 / 40 27-440  
info@philipp-group.de  
www.philipp-group.de

**PHILIPP GmbH**  
Roßlauer Strasse 70  
D-06869 Coswig/Anhalt  
Tel: + 49 (0) 34903 / 6 94-0  
Fax: + 49 (0) 34903 / 6 94-20  
info@philipp-group.de  
www.philipp-group.de

**PHILIPP GmbH (TB KLEIN)**  
Sperberweg 37  
D-41468 Neuss  
Tel: + 49 (0) 2131 / 3 59 18-0  
Fax: + 49 (0) 2131 / 3 59 18-10  
info@philipp-group.de  
www.philipp-group.de

**Our Technical support: [technik@philipp-gruppe.de](mailto:technik@philipp-gruppe.de)**